

Approval body for construction products
and types of construction

Bautechnisches Prüfamt

An institution established by the Federal and
Laender Governments



European Technical Assessment

ETA-08/0231
of 26 May 2014

General Part

Technical Assessment Body issuing the
European Technical Assessment:

Deutsches Institut für Bautechnik

Trade name of the construction product

K-A-L-M bonded anchor VPK-SF

Product family
to which the construction product belongs

Bonded anchor for use in non-cracked concrete

Manufacturer

KALM
Befestigungssysteme GmbH
Marie-Curie-Straße 5
67661 Kaiserslautern
DEUTSCHLAND

Manufacturing plant

KALM
Befestigungssysteme GmbH
Marie-Curie-Straße 5
67661 Kaiserslautern
DEUTSCHLAND

This European Technical Assessment
contains

11 pages including 3 annexes which form an integral part
of this assessment

This European Technical Assessment is
issued in accordance with Regulation (EU)
No 305/2011, on the basis of

Guideline for European technical approval of "Metal
anchors for use in concrete", ETAG 001 Part 5: "Bonded
anchors", April 2013,
used as European Assessment Document (EAD)
according to Article 66 Paragraph 3 of Regulation (EU)
No 305/2011.

This version replaces

ETA-08/0231 issued on 17 June 2013

The European Technical Assessment is issued by the Technical Assessment Body in its official language. Translations of this European Technical Assessment in other languages shall fully correspond to the original issued document and shall be identified as such.

Communication of this European Technical Assessment, including transmission by electronic means, shall be in full. However, partial reproduction may only be made with the written consent of the issuing Technical Assessment Body. Any partial reproduction has to be identified as such.

This European Technical Assessment may be withdrawn by the issuing Technical Assessment Body, in particular pursuant to information by the Commission according to Article 25 Paragraph 3 of Regulation (EU) No 305/2011.

Specific Part

1 Technical description of the product

The K-A-L-M bonded anchor VPK-SF is a bonded anchor consisting of a mortar capsule VPK-SF and a threaded anchor rod with hexagon nut and washer of sizes M8, M10, M12, M16, M20 and M24. The anchor rod (including nut and washer) is made of galvanised steel, hot-dip galvanised steel, stainless steel or made of high corrosion resistant steel.

The mortar capsule is placed in the hole and the anchor rod is driven by machine with simultaneous hammering and turning. The anchor rod is anchored via the bond between anchor rod, chemical mortar and concrete.

The product description is given in Annex A.

2 Specification of the intended use in accordance with the applicable European Assessment Document

The performances given in Section 3 are only valid if the anchor is used in compliance with the specifications and conditions given in Annex B.

The verifications and assessment methods on which this European Technical Assessment is based lead to the assumption of a working life of the anchor of at least 50 years. The indications given on the working life cannot be interpreted as a guarantee given by the producer, but are to be regarded only as a means for choosing the right products in relation to the expected economically reasonable working life of the works.

3 Performance of the product and references to the methods used for its assessment

3.1 Mechanical resistance and stability (BWR 1)

Essential characteristic	Performance
Characteristic resistance for tension loads	See Annex C 1
Characteristic resistance for shear loads	See Annex C 2
Displacements under tension loads	See Annex C 1
Displacements under shear loads	See Annex C 2

3.2 Safety in case of fire (BWR 2)

Essential characteristic	Performance
Reaction to fire	Anchorage satisfy requirements for Class A1
Resistance to fire	No performance determined (NPD)

3.3 Hygiene, health and the environment (BWR 3)

Regarding dangerous substances there may be requirements (e.g. transposed European legislation and national laws, regulations and administrative provisions) applicable to the products falling within the scope of this European Technical Assessment. In order to meet the provisions of Regulation (EU) No 305/2011, these requirements need also to be complied with, when and where they apply.

3.4 Safety in use (BWR 4)

The essential characteristics regarding Safety in use are included under the Basic Works Requirement Mechanical resistance and stability.

3.5 Protection against noise (BWR 5)

Not applicable.

3.6 Energy economy and heat retention (BWR 6)

Not applicable.

3.7 Sustainable use of natural resources (BWR 7)

The sustainable use of natural resources was not investigated.

3.8 General aspects

The verification of durability is part of testing the essential characteristics. Durability is only ensured if the specifications of intended use according to Annex B are taken into account.

4 Assessment and verification of constancy of performance (AVCP) system applied, with reference to its legal base

According to Decision of the Commission of 24 June 1996 (96/582/EC) (OJ L 254 of 08.10.96 p. 62-65), the system of assessment and verification of constancy of performance (see Annex V and Article 65 Paragraph 2 to Regulation (EU) No 305/2011) given in the following table applies.

Product	Intended use	Level or class	System
Metal anchors for use in concrete (heavy-duty type)	For fixing and/or supporting concrete structural elements or heavy units such as cladding and suspended ceilings	—	1

5 Technical details necessary for the implementation of the AVCP system, as provided for in the applicable European Assessment Document

Technical details necessary for the implementation of the AVCP system are laid down in the control plan deposited at Deutsches Institut für Bautechnik.

Issued in Berlin on 26 May 2014 by Deutsches Institut für Bautechnik

Dr.-Ing- Karsten Kathage
Vice President

Beglaubigt:
Baderschneider

Installation anchor

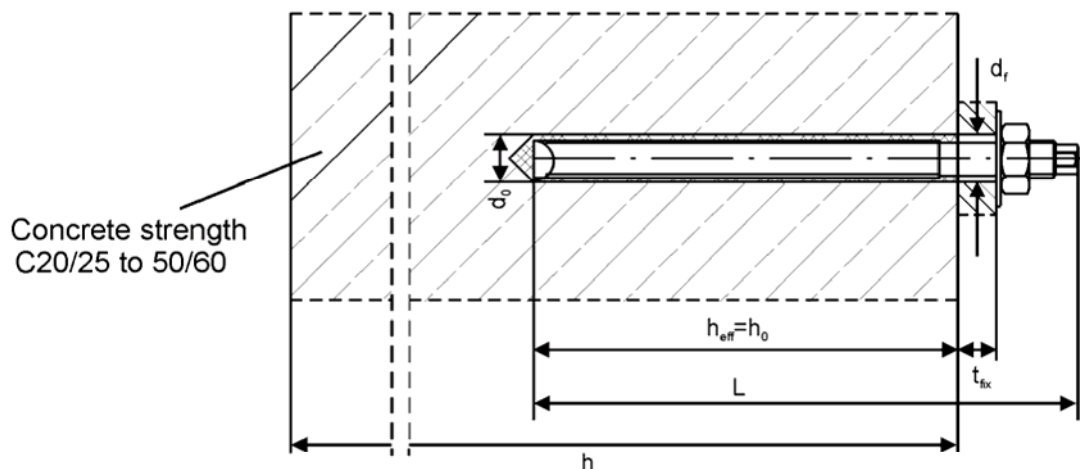

Mortar Capsule

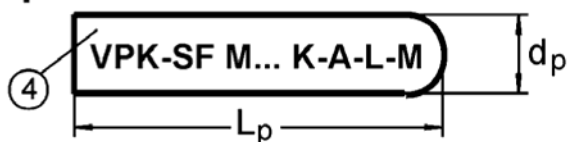

Threaded rod for VPK-SF

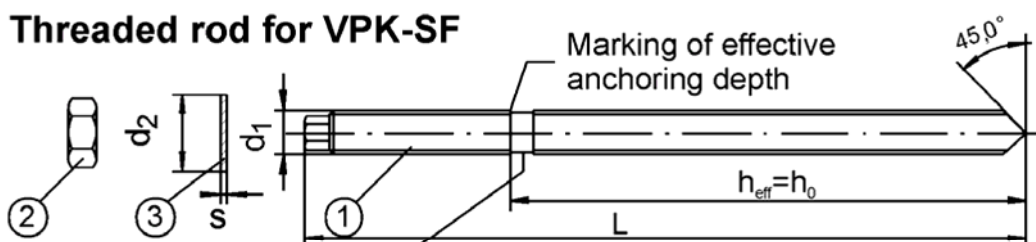

Marking 1

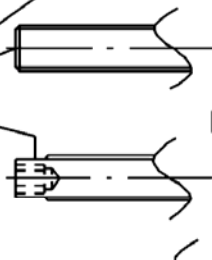

Marking1: Identifying mark of manufacturing plant K
Size of thread M...
Example KM10, for stainless steel plus E,
for high corrosion plus H

Marking 2



Marking2: Example: , for stainless steel plus E,
for high corrosion plus H

For threaded rod without marking of the effective depth, the depth must be marked manual before use.

K-A-L-M bonded anchor VPK-SF

Product description

Installed condition
Mortar Capsule, Threaded rod

Annex A 1

Table A1: Dimensions

Anchor size			M8	M10	M12	M16	M20	M24
Threaded rod	Ø d ₁	[mm]	M8	M10	M12	M16	M20	M24
	L ≥	[mm]	90	100	120	140	190	235
	h _{eff}	[mm]	80	90	110	125	170	210
Mortar Capsule	d _p	[mm]	9	10,5	12,5	16,5	23	23
	L _p		80	85	95	95	160	190

Table A2: Materials

Part	Designation	Material	
		Steel, zinc plated ≥ 5 µm plated acc. to EN ISO 4042:1999	Steel, hot-dip galvanized ≥ 40 µm acc. to EN ISO 1461:2009
1	Threaded rod	Steel DIN EN 10087:1998, DIN EN 10263:2001 Property class 5.8, acc. to EN 1993-1-8:2005+AC:2009	
2	Hexagon nut EN ISO 4032:2012	Steel Property class 8, acc. to EN ISO 898-2:2012	
3	Washer EN ISO 7089:2000 EN ISO 7093:2000 EN ISO 7094:2000	Steel, galvanized	Steel, hot-dip galvanized
Part	Designation	Material	
		Stainless steel A4	High corrosion resistant steel (HCR)
1	Threaded rod	Material 1.4401, 1.4404, 1.4571, 1.4578, EN 10088:2005, Property class 70, EN ISO 3506-1:2009	Material 1.4529, 1.4565, EN 10088:2005, Property class 70, EN ISO 3506-1:2009
2	Hexagon nut EN ISO 4032:2012	Material, 1.4401, 1.4404, 1.4571, EN 10088:2005, Property class 70, EN ISO 3506-2:2009	Material 1.4529, 1.4565, EN 10088:2005, Property class 70, EN ISO 3506-2:2009
3	Washer EN ISO 7089:2000 EN ISO 7093:2000 EN ISO 7094:2000	Material, 1.4401, 1.4404, 1.4571, EN 10088:2005	Material 1.4529, 1.4565, EN 10088:2005
Part	Designation	Material	
4	Mortar capsule	Glass, Quartz, Resin, Hardener	

K-A-L-M bonded anchor VPK-SF

Product description
Dimensions
Materials

Annex A 2

Specifications of intended use

Anchorage subject to:

- Static and quasi-static loads: all sizes.

Base materials:

- Reinforced or unreinforced normal weight concrete according to EN 206-1:2000.
- Strength classes C20/25 to C50/60 according to EN 206-1:2000.
- Non-cracked concrete.

Temperature Range:

- -40°C to 80°C (max long term temperature +50 °C and max short term temperature +80 °C)

Use conditions (Environmental conditions):

- Structures subject to dry internal conditions (zinc coated steel, stainless steel or high corrosion resistant steel).
- Structures subject to external atmospheric exposure (including industrial and marine environment) and to permanently damp internal condition, if no particular aggressive conditions exist (stainless steel or high corrosion resistant steel).
- Structures subject to external atmospheric exposure and to permanently damp internal condition, if other particular aggressive conditions exist (high corrosion resistant steel).

Note: Particular aggressive conditions are e.g. permanent, alternating immersion in seawater or the splash zone of seawater, chloride atmosphere of indoor swimming pools or atmosphere with extreme chemical pollution (e.g. in desulphurization plants or road tunnels where de-icing materials are used).

Design:

- Anchorages are designed under the responsibility of an engineer experienced in anchorages and concrete work.
- Verifiable calculation notes and drawings are prepared taking account of the loads to be anchored. The position of the anchor is indicated on the design drawings (e. g. position of the anchor relative to reinforcement or to supports, etc.).
- Anchorages are designed in accordance with ETAG 001, Annex C, design method A, Edition August 2010

Installation:

- Dry or wet concrete: all sizes.
- Flooded holes (not sea water): M12 to M24.
- Hole drilling by hammer drilling.
- Anchor installation carried out by appropriately qualified personnel and under the supervision of the person responsible for technical matters of the site.
- The mortar capsule is placed into the drilled hole; connecting the anchor rod with the percussion drill by using a corresponding adapter; driving the anchor rod into the mortar capsule by simultaneous hammering and turning of the drill; if the anchorage depth is achieved the drill must be stopped immediately by using some pressure; if the anchor is properly installed mortar must be visible at the member surface.

K-A-L-M bonded anchor VPK-SF

Intended Use
Specifications

Annex B 1

Table B1: Installation parameters

Anchor size			M8	M10	M12	M16	M20	M24
Nominal diameter of drill hole	d_0	[mm]	10	12	14	18	25	28
Cutting diameter of drill hole	d_{cut}	[mm]	10,45	12,45	14,5	18,5	25,5	28,5
Depth of drill hole	h_0	[mm]	80	90	110	125	170	210
Effective embedment depth	h_{eff}	[mm]	80	90	110	125	170	210
Diameter of clearance hole in fixture	d_f	[mm]	9	12	14	18	22	26
Installation torque	T_{inst}	[Nm]	10	20	40	60	120	150
Minimum member thickness	h_{min}	[mm]	110	120	150	160	220	300
Minimum edge distance	c_{min}	[mm]	60	70	85	95	130	160
Minimum spacing	s_{min}	[mm]	60	70	85	95	130	160

Cleaning Tools

Steel Brush



Size	M	8	10	12	16	20	24	
Diameter of steel brush	d	[mm]	12	14	16	20	27	30

Blow Pump ABK (Standard Cleaning)



Compressed Air (Premium Cleaning)

Use a conventional compressed air pump with a pressure $\geq 6\text{bar}$

Table B2: Minimum curing time

Temperature in the anchorage base	Minimum curing time in dry concrete [min]	Minimum curing time in wet concrete [min]
-5°C to 0°C	360	720
0°C to 5°C	180	360
5°C to 10°C	90	180
10°C to 20°C	40	80
> 20°C	20	40

K-A-L-M bonded anchor VPK-SF

Intended Use

Installation parameters, Cleaning and Setting Tools
Minimum curing time

Annex B 2

Installation instructions

Standard Cleaning

- Drill the hole.
Blow out the dust with the blow pump ABK twice.
- Brush the drill hole twice with the steel brush DBK,
again blow out the dust with the blow pump ABK twice.
- Check the capsule before using. The capsule can be used
if it is undamaged and the resin is vicious. Insert the capsule
into the drill hole.
- Drive the anchor stud into the drill hole with the help of a
percussion drill. Notice the curing times. In case of a wet base
material the curing time has to be doubled.
- Considering the curing times the nut can be tightened.
Respect the torque moment.

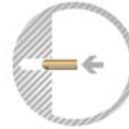

Premium Cleaning

- Drill the hole.
Blow out the dust with compressed air (>6 bar) twice.
- Brush the drill hole twice with the steel brush DBK,
again blow out the dust with compressed air (>6 bar) twice.
- Check the capsule before using. The capsule can be used
if it is undamaged and the resin is vicious. Insert the capsule
into the drill hole.
- Drive the anchor stud into the drill hole with the help of a
percussion drill. Notice the curing times. In case of a wet base
material the curing time has to be doubled.
- Considering the curing times the nut can be tightened.
Respect the torque moment.



For all installations the max setting time of 10 seconds should not be exceeded.

K-A-L-M bonded anchor VPK-SF

Intended Use
Installation instructions

Annex B 3

Table C1: Characteristic values of resistance under tension loads

anchor size			M8	M10	M12	M16	M20	M24
Steel failure								
Characteristic resistance, Steel property class 5.8	$N_{Rk,s}$	[kN]	17	26	38	72	114	165
Characteristic resistance, Steel property class 70	$N_{Rk,s}$	[kN]	23	34	52	97	153	222
Combined pull-out and concrete cone failure								
Characteristic resistance in non-cracked concrete 50/80°C Standard Cleaning	$N_{Rk,p}$	[kN]	9	12	16	25	40	60
Characteristic resistance in non-cracked concrete 50/80°C Premium Cleaning	$N_{Rk,p}$	[kN]	12	16	25	35	60	75
Increasing factors for concrete ψ_c	C 30/37		1,08					
	C 40/50		1,15					
	C 50/60		1,19					
Splitting failure								
edge distance	$c_{cr,sp}$	[mm]	120	135	165	190	255	315
spacing	$s_{cr,sp}$	[mm]	240	270	330	380	510	630
Installation safety factor in dry and wet concrete	γ_2	[-]	1,2					
Installation safety factor in flooded holes	γ_2	[-]	-	1,2				

Table C2: Displacements under tension loads

anchor size			M 8	M 10	M 12	M 16	M 20	M 24
Displacement	δ_{N0}	[mm]	0,1	0,1	0,1	0,2	0,3	0,3
Displacement	$\delta_{N\infty}$	[mm]	1,1	1,1	1,1	2,2	3,3	3,3

K-A-L-M bonded anchor VPK-SF

Performances

Characteristic values of resistance under tension loads
Displacements under tension loads

Annex C 1

Table C3: Characteristic values of resistance under shear loads

anchor size			M8	M10	M12	M16	M20	M24
Steel failure without lever arm								
Characteristic resistance, Steel property class 5.8	$V_{Rk,s}$	[kN]	8	13	19	36	57	83
Characteristic resistance, Steel property class 70	$V_{Rk,s}$	[kN]	11	17	26	49	77	111
Steel failure with lever arm								
Characteristic bending moment, Steel property class 5.8	$M^0_{Rk,s}$	[Nm]	16	30	56	144	285	498
Characteristic bending moment, Steel property class 70	$M^0_{Rk,s}$	[Nm]	22	41	75	194	384	670
Concrete pry-out failure								
Factor k in equation (5.6) of ETAG 001, Annex C, section 5.2.3.3			2,0					
Installation safety factor	γ_2	[-]	1,0					
Concrete edge failure								
effective length of anchor in shear loading	l_f	[mm]	80	90	110	125	170	210
outside diameter of anchor	d_{nom}	[mm]	10	12	14	18	25	28
Installation safety factor	γ_2	[-]	1,0					

Table C4: Displacements under shear loads

anchor size			M 8	M 10	M 12	M 16	M 20	M 24
Displacement	δ_{V0}	[mm]	1,5	1,6	1,8	2,0	2,5	3,0
Displacement	$\delta_{V\infty}$	[mm]	2,3	2,4	2,7	3,0	3,8	4,5

K-A-L-M bonded anchor VPK-SF

Performances

Characteristic values of resistance under shear loads
Displacements under shear loads

Annex C 2